

## **Recent development of numerical simulations for aerodynamics of high-speed trains: wind gust modeling and shape optimization**

**Siniša Krajnović**

Department of Applied Mechanics  
Chalmers University, Gothenburg, Sweden  
e-mail: sinisa@chalmers.se

**Summary** The present paper presents some recent development of numerical simulations for flows around high-speed trains. The first part of the paper deals with time-dependent simulations of a wind gust's influence on a train. Here flow around an ICE2 train is simulated using detached eddy simulation. A shape optimization strategy for aerodynamics of high-speed trains based on metamodels is presented in the second part of the paper.

### **DES of the flow around a high-speed train leaving a tunnel under the influence of a wind gust**

Technique of detached eddy simulation has now matured to be used in flows that have large industrial relevance but are difficult to predict with traditional RANS approaches and very difficult (often impossible) to study with experimental techniques. This paper aims to present a DES simulation of one such flow where a high-speed train is leaving a tunnel and is influenced by a wind that varies in space. Such a flow situation is interesting for high-speed trains as it can jeopardize safety of the train and cause derailment or overturning. Unfortunately it is difficult to study such a flow in experimental conditions due to difficulties to model wind gust as well as other boundary conditions (moving floor). Besides, it is impossible to model such a flow with steady RANS approach due to the unsteady nature of the flow.

Here, we first propose a new model for wind gusts based on previous experimental observations. The mathematical model of the wind gust consist of a damping function, a saturation function and sinusoidal functions. The amplitude of the damping function prescribes the maximum wind-gust speed. Perturbations of the wind gust are controlled using sinusoidal functions and the saturation function limits the speed of the wind after the passage of the wind gust. Our numerical model of the wind gust is defined as follows:  $V(t) = G_1 + G_2 + G_3$  where  $G_1 = B_1 t e^{-B_2 t}$ ,  $G_2 = V_3 \operatorname{erf}(B_3 t)$  and  $G_3 = B_4 e^{-B_5 t} \sin(\Omega t)$ .  $B_1 - B_5$  and  $\Omega$  are model constants prescribed to fit the desired wind-gust conditions.

The computational domain for the train leaving the tunnel is shown in Fig. 1a. The simulation is first run with only one inlet and the constant velocity profile at the inlet of 56 m/s corresponding to a train moving at speed of 200 km/h. When the flow has developed, the wind gust condition is applied on both lateral walls of the domain. This is done by changing the lateral boundary condition to that described above, meaning that the wind-gust boundary condition above (that is a function in time) is translated to a function in space that is changing in time.

The train geometry is relatively detailed containing bogies, rotating wheels, plugs, inter-car gaps and rails (Fig. 1b). In our previous work on DES of flow around a bus in a cross wind [1], we

have shown that DES predicts results in very good agreement with the experimental data when the representation of the geometry of the bus was similar (in terms of details) to that of the train in the present work.

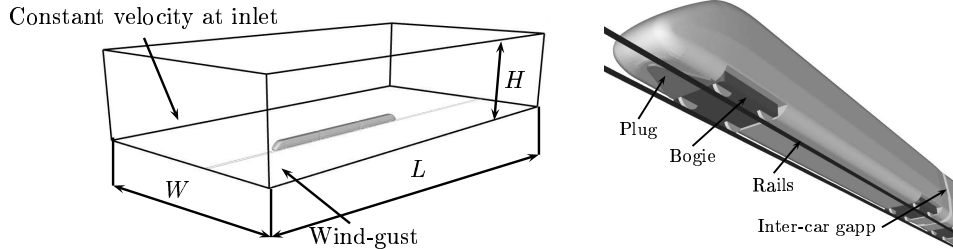

Figure 1: a) Geometry of the computational domain of the high-speed train leaving the tunnel. b) Part of the geometry of the train showing the loco from below.

Figure 2 shows the development of the flow around the train leaving the tunnel. As seen in this figure, a number of vortices are formed as the train leaves the tunnel under the influence of a wind gust. Trailing vortex emerging from the upper corner on the lee side of the loco dominates the flow but other vortices are also formed from the interaction of the wind gust with the inter-car gaps, wheels, bogies and plugs. These structures form very rapidly as the result of the nature of the wind gust causing the variation in the aerodynamic forces and moments.

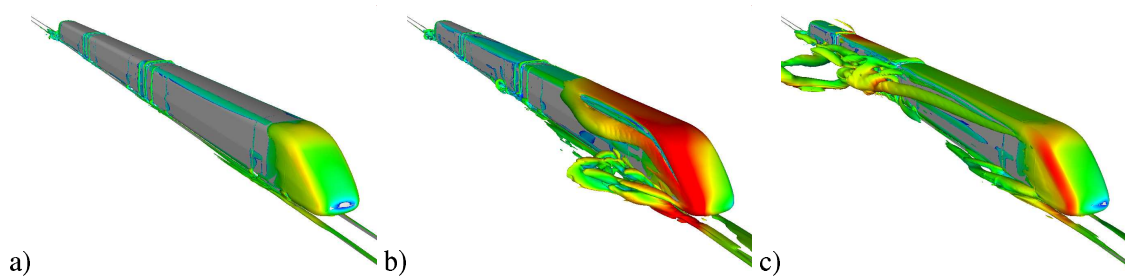

Figure 2: An isosurface of the second invariant of the velocity gradient colored with velocity magnitude. Figure a) shows the flow at the time when the wind gust has reached the train. The time difference between two pictures is 0.72s.

### Multi-objective shape optimization for aerodynamics of high-speed trains

Optimization of aerodynamic properties of high speed trains was in the past handled as a trial-and error procedure which relies on knowledge of engineers. Although such a design procedure often leads to an improvement of the aerodynamic properties of the starting design, there is no guarantee that an optimal design will be achieved. Besides, a vehicle aerodynamic optimization problem is always a multi-objective problem meaning that several objectives such as drag, crosswind stability or aero acoustic noise must be optimized simultaneously. This requires often that compromises are made between the objective functions. Thus a rigorous numerical algorithm that is capable of analyzing a design space in a systematic way and providing a design that fulfils specifications is desired.

Here we suggest constructions of approximations of objective functions that will replace costly runs of Navier-Stokes solvers. Such approximations are often denoted metamodels or surrogate based models and the basic idea behind these is to use relatively small number of numerical experiments (runs of Navier-Stokes solver) to construct an approximate model that is valid in the

entire design space. If the true nature of a Navier-Stokes solver is  $y = f(x)$  then a metamodel is  $\hat{y} = g(x)$  where  $x = (x_1, x_2, \dots, x_N)$  are the design variables. The metamodel contains an error  $\varepsilon = y - \hat{y}$  that in physical experiments is partly due to the modeling error and partly due to measurement errors. In numerical experiments the modeling error is a result of the choice of the metamodel while the closest to the measurement error (which is random in physical experiments) is the numerical error. Once such a metamodel is constructed, a direct relationship between design variables and objective is available. Furthermore, as the evaluation of the objective functions using metamodels is inexpensive, fast analysis of the design domain using e.g. genetic algorithm is possible.

Here we present our optimization technique on two test cases. The aim of the first case is to optimize the shape of the front of a generic train for crosswind stability. The shape of the front of the train is shown in Fig. 3a.

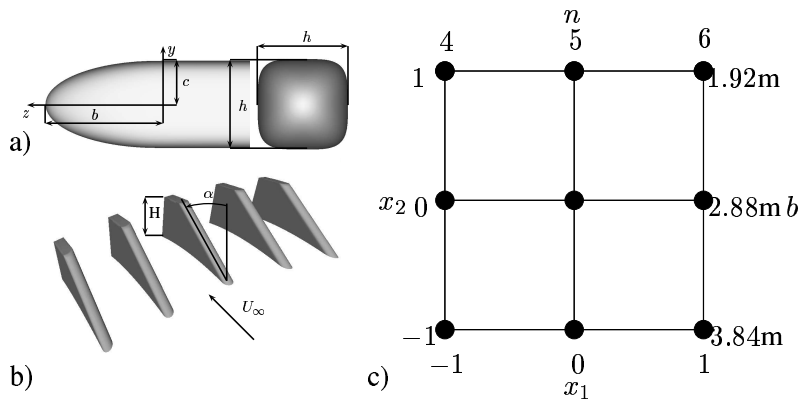

Figure 3: a) Shape of the front of the train from a side and upstream of the train. b) Vortex generators that are placed on the rear part of a high-speed train. c) Center composite design for the optimization of the nose of the generic train.

The profile of the cross section of this model is defined by  $|y|^n + |z|^n = c^n$ . The second equation that describes the shape of the front from a lateral side is  $z^2/b^2 + y^2/c^2 = 1$ . Here,  $b$  is the length of the front,  $c = h/2$  and  $h = 3.0m$  is the height of the train (see Fig. 3a). The length of the train excluding the front and the rear (which are identical) is 30m. The length of the front,  $b$ , (see Fig. 3a) and the curvature of the cross section,  $n$ , are chosen as design variables that are varied in the optimization procedure.

The second shape that is optimized in the present work is that of vortex generators placed on the rear of an ICE 2 high-speed train with the purpose of decrease of pressure drag. In the present study a relatively short train is used containing only 1.25 length of a car of a real ICE2 train. Due to such a short train, the aerodynamic drag is dominated by the pressure drag and we expect the vortex generating devices to decrease the total drag. The shape of the VG is shown in Fig. 3b and in the present study we have varied two design variables: the height of the VG,  $H$ , and the angle of the streamwise slanted edge of the VG,  $\alpha$  (Fig. 3b).

In the present study we are using center composite design (CCD). This design for the nose shape optimization is presented in Fig. 3c. Response surface models in form of second and third-order polynomials are used as surrogate models for all objective functions. From the previous work [2] we know that a RSM based on a subset of the regressors in the full RSM is often superior than the

full RSM. In the present work, a backward elimination procedure based on  $t$  statistics is used to discard terms and improve the prediction accuracy.

When the optimal design was evaluated using new CFD simulation, we found that the RSM of the two aerodynamic coefficients were accurate within one percent. As a second part in our optimization strategy we have computed Pareto-optimal solutions that allow us to make trade-offs between responses. Pareto optimal fronts are obtained using an evolutionary algorithm (NSGA-II) according to Deb et. al. [3]. The present work shows that our approach is very efficient in terms of optimization time and computational requirements. Instead of large number of CFD simulations required in traditional gradient-based search algorithms only small number of CFD simulations were required to find an optimal design of the front of the high-speed train.

### **Concluding remarks**

The present paper has demonstrated how flow phenomena such as influence of a wind gust on a high-speed train can be studied using time-dependent numerical simulations. Being inherent time-dependent, such a flow was in past impossible to study using traditional steady RANS simulations and very difficult to study in experimental facilities due to practical constraints (such as providing proper boundary conditions). Besides, we have presented an efficient multi-objective optimization technique that uses simple approximations of objective functions in form of response surface approximations instead of running computationally expensive Navier-Stokes solvers. The center composite design used in the present work belongs to so called design of experiments (DOE). DOE were originally developed for physical experiments but are often used for design of computer experiments. Beside the DOE which are more suited for physical experiments, there is also another strategy called DACE which is more suited for design and analysis of computer experiments. In addition there are also other metamodel which are more appropriate for modeling of objectives from computer experiments. We shall in the final paper present an implementation of such a metamodel called Kriging model together with latin-hypercube DACE.

### **Acknowledgments**

This work is financed by Banverket (Swedish National Rail Administration) under contracts no.S05-3157/AL50 and no. HK 06-1337/AL50 and it is a part of the project called Gröna Tåget. FLUENT Sweden and Bombardier Transportation are supporting the project.

### **References**

- [1] H. Hemida and S. Krajnović. DES of the Flow Around a Realistic Bus Model Subjected to a Side Wind with 30° Yaw Angle *The fifth IASME / WSEAS International Conference on FLUID MECHANICS and AERODYNAMICS.*, Athens, Greece, 25-27 August, (2007).
- [2] S. Krajnović. Aerodynamic Optimization of Vehicles Using Computational Fluid Dynamics and Response Surface Methodology *XXI International Automotive Conference SCIENCE & MOTOR VEHICLES* Paper NMV0724, Beograd, Serbia, 2007.
- [3] K. Deb and S. Agrawal and A. Pratap and T. Mayarivan. A Fast and Elitist Multiobjective Genetic Algorithm for Multi-objective Optimization: NSGA-II, *Parallel problem solving from nature VI conference*, Paris, pp. 849-858, 2000.